

SEAL SPEC K23-N

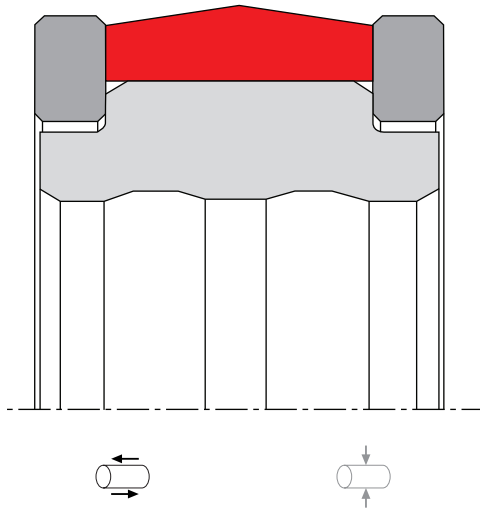

description

profile ring-activated compact piston seal with integrated back-up rings, excellent static sealing capacity. external guiding elements required.

- + asymmetric double-acting compact piston seal set, consisting of a gliding part, a preload element and backup elements.
- + interference fit on the inside diameter.
- + various materials are available for different purposes.
- + easy to slip over stepped grooves (see notes on installation and recommended mounting space).
- + highest degree of sealing across a wide temperature range.
- + for pressures up to 400 bar as a seal between pressurised spaces.
- + excellent sealing in all pressure ranges.
- + very good static sealing.
- + suitable for short and long travel.
- + due to compact design an inexpensive construction of piston is possible.
- + no drag pressure build-up.
- + improved guiding properties due to activated back-up elements.
- + because of the excellent sealing effect, a fluid transport between the pressurised spaces is practically prevented.
- + 2 groove on the inside diameter of the preload element for local limiting the preload force.

category of profile

machined product only

double acting

the K23-N seal is designed for use as a piston seal

area of application; hydraulics

- reciprocating pistons in hydraulic cylinders.
- as piston seals for clamping function resp. for low requests for movement.

note

- high frictional force
- the ratio between nominal width and sealing height cs/H should be approximately $1/2.5$ (essentially according to ISO 6547 housings for piston seals with integrated guide rings).
- the guiding of the piston has to be assured by additional guiding elements.

function

K23-N profiles are compact piston seals designed to seal between two pressurised spaces; mainly for reciprocating movements. the design is based on application in standard hydraulic systems with conventional hydraulic oils. the operating parameters are as defined in the sealing data sheet and material data. requirements deviating from these parameters can be met to a certain degree by changing the geometry in the software program.

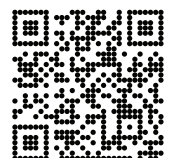

operating parameter & material

| sealing element | material energizer | back-up ring | temperature | max surface speed | max pressure ¹ | hydrolysis | dry running | wear resistance |
|-----------------|--------------------|---------------------|--------------------|-------------------|---------------------------|------------|-------------|-----------------|
| PU | NBR | POM/PA ² | -30 °C ... +100 °C | 0,5 m/s | 400 bar (40 MPa) | - | + | + |
| HPU | NBR | POM/PA ² | -20 °C ... +100 °C | 0,5 m/s | 400 bar (40 MPa) | - | + | + |
| LTPU | NBR | POM/PA ² | -30 °C ... +100 °C | 0,5 m/s | 400 bar (40 MPa) | - | + | + |
| SPU | NBR | POM/PA ² | -20 °C ... +100 °C | 0,7 m/s | 400 bar (40 MPa) | - | + | + |
| GPU | NBR | POM/PA ² | -30 °C ... +100 °C | 0,5 m/s | 400 bar (40 MPa) | - | + | + |

¹ pressure ratings are dependent on the size of the extrusion gap.

++ particularly suitable

+ suitable

o conditional suitable

- not suitable

² POM up to ø260 mm, PA above ø260 mm

the stated operation conditions represent general indications. it is recommended not to use all maximum values simultaneously. surface speed limits apply only to the presence of adequate lubrication film.

for detailed information regarding chemical resistance please refer to our „list of resistance“. for increased chemical and thermal resistance resp. for higher gliding speeds PTFE-materials should be used (e.g. profile K09-F or a different sealing system)

note on special material:

other materials such as Viton, Silicone, EPDM, H-NBR, etc., can be used for the preload element, but they are only useful in specific cases (temperature or chemical influences). the temperature limits are determined by the guide- and support parts, using special materials can expand the temperature limits.

gap dimension

by using support parts, the extrusion gap for the sealing part is already integrated in the seal. the gap between piston and housing should not exceed 0,4 mm.

surface quality

| surface roughness | Rtmax (µm) | Ra (µm) |
|-------------------|------------|----------|
| sliding surface | ≤2,5 | ≤0,1-0,5 |
| bottom of groove | ≤6,3 | ≤1,6 |
| groove face | ≤15 | ≤3 |

tolerance recommendation

| seal housing tolerance | |
|------------------------|----|
| Ød | h9 |
| Ød1 | h8 |
| ØD | H9 |

mode of installation

first of all the preload element should be slipped over the piston and snapped into the groove, then the first backup element should be placed into the groove, followed by the gliding part and then the second backup element. the installation of the backup elements as well as the gliding part is generally trouble-free, at installation of the preload element the material deformation should not exceed the value of 30%, otherwise the permanent deformation would be too large.

insertion chamfer

in order to avoid damage to the piston seal during installation, the piston and the housing is to be chamfered and rounded as shown in the "recommended mounting space" drawing. the size of chamfer depends on the seal type and profile width.

| cs (mm) | c (mm) | |
|---------|-----------------|-----------------|
| | α = 15° ... 20° | α = 20° ... 30° |
| 5 | 4 | 2,5 |
| 7,5 | 5 | 4 |
| 10 | 6 | 5 |
| 12,5 | 8,5 | 6,5 |
| 15 | 10 | 7,5 |
| 20 | 13 | 10 |

instead of a chamfer, the piston can also be designed with a radius. recommended size of the radius is equal to size of chamfer (R=c).

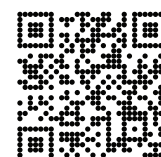

SEAL SPEC K23-N

recommended mounting space

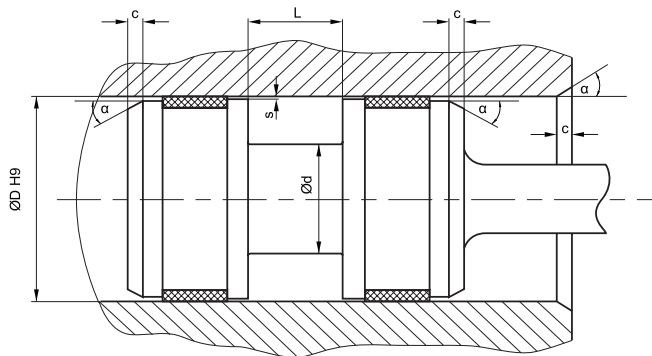

plastic guiderings (wearbands) have to feature a adequate cutting gap (recommendation: 2-5% of D). if metallic guides are used, spiral grooves shall be provided. smaller values for Hmin will ease the installation (reduced elongation and mounting force) but the height of the retaining collar has to be sufficient to assure a stable fit in the housing (larger than $cs/2$, smaller retaining collars will increase the danger of eversion of the profile in case of occuring drag pressure). in order to avoid drag pressure built up in case of back-to-back arrangement, the distance between the seals should be as small as possible.

fitted

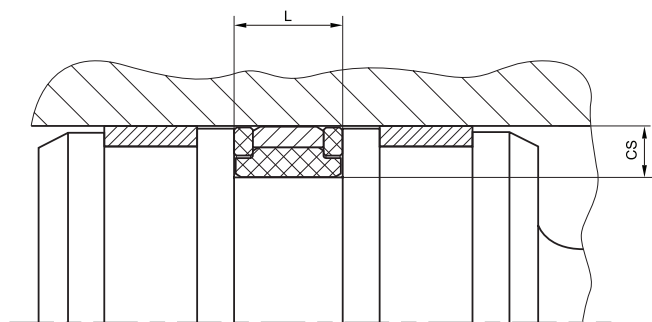

seal & housing recommendations

please note that we are able to produce those profiles to your specific need or any non standard housing. for detail measurements, please see seal-mart catalog...

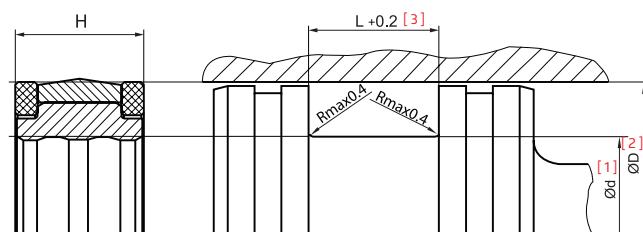

| ØD [mm] | L [mm] | $cs = (\text{ØD} - \text{Ød})/2$ |
|-------------|--------|----------------------------------|
| [2] | [3] | |
| 20 ~ 49,9 | 12,5 | 5 |
| 50 ~ 79,9 | 20 | 7,5 |
| 80 ~ 149,9 | 25 | 10 |
| 150 ~ 399,9 | 32 | 12,5 |
| 400 ~ 750 | 36 | 15 |
| > 750 | 40 | 20 |

the ratio between nominal width and seal height cs/H should not drop below 1/125. therefore we recommend the following housing heights.

